

# EMG

## PRESSES



**R U Č N Í L I S Y**  
**P N E U M A T I C K É L I S Y**  
**D Í L E N S K É H Y D R A U L I C K É L I S Y**

LONG S.A. - Z.I. des Grives  
74150 MARIGNY-ST-MARCEL - France  
Tél. +33 (0)4 50 01 11 58  
Fax +33 (0)4 50 01 14 85  
commercial@emgpresses.com  
www.emgpresses.com

PRAMARK, s.r.o.  
Křížová 6, 150 05 Praha 5  
Česká republika  
Tel. : +420 251 56 10 29  
Fax : +420 251 56 33 85  
e-mail: pramark@pramark.cz  
www.pramark.cz



# RUČNÍ LISY

Tyto obzvláště robustní modely jsou nejčastěji používány pro montážní operace, spojování, malého obrubování, zasazování atd.

Tyto lisy nabízejí veškeré záruky při standardním použití

- Beran zajištěn proti rotaci
- Nastavitelný zdvih

**Hřebenové lisy: 2HR, 3HR & 4HR**

Lineární tlak je konstantní po celou dobu zdvihu, v závislosti na vyvinuté síle

**Pákové lisy : 5HR, 7HR, 15HR, 20HR, 15HR LP & 20HR LP**

Maximální síla je dosažena na konci zdvihu

	2HR	3HR	4HR	5HR	7HR	15HR	20HR	15HR LP	20HR LP
Hřebenové lisy	▼	▼	▼						
Pákové lisy				▼	▼	▼	▼	▼	▼
Síla	200 kg	400 kg	600 kg	500 kg	700 kg	1 500 kg	2 000 kg	1 500 kg	2 000 kg
Zdvih	0-50 mm	0-80 mm	0-100 mm	0-50 mm	40 mm	30-60 mm	60 mm	30-60 mm	60 mm
Světlá výška	54-200 mm	35-270mm	46-280 mm	42-185 mm	35-230 mm	60-250 mm	120-280mm	220 mm	250 mm
Hloubka	72 mm	80 mm	95 mm	72 mm	95 mm	102 mm	130 mm	220 mm	250 mm
Hmotnost	8 kg	17 kg	25 kg	9 kg	25 kg	32 kg	65 kg	55 kg	70 kg

	2HR	3HR	4HR	5HR	7HR	15HR	20HR	15HR LP	20HR LP
A	10	14	16	10	14	16	16	16	16
B	20	30	35	20	30	40	45	40	45
C	100	130	160	100	160	200	220	200	220
D	70	118	145	70	145	180	200	180	200
E	14	14	14	14	14	32 <sup>H7</sup>	32 <sup>H7</sup>	32 <sup>H7</sup>	32 <sup>H7</sup>
F	72	65	80	72	80	100	130	220	250
G	84	127	138	84	138	45	225	72	72
H	60	165	200	60	200	175	175	160	160
I	-	-	-	-	-	205	-	330	395
J	100	195	240	100	240	200	220	190	190
K	165	210	250	165	250	285	350	490	560
L	45	30	31	45	31	87	80	119	138
M	-	40	50	-	50	-	-	-	-
N	327	380	400	327	400	495	650	563	710
O	470	600	650	581	700	880	990	990	1045
P	-	15.5	15.5	-	15.5	21	21	21	21
Q	-	8	8	-	8	12	12	12	12
R	-	7.5	7.5	-	7.5	9	9	9	9
S	-	10	10	-	10	9	9	9	9
T	10	12	12	10	12	12	12	12	12
U	23	26	26	23	26	26	26	26	26
V	M6	M8	M8	M6	M8	M8	M8	M8	M8

Blokační návratový systém dostupný pouze pro pákové lisy



Nastavení mechanického dorazu (1 díl  $l = 0,02\text{mm}$ ).  
Dostupné pro všechny ruční verze.

2HR - 3HR - 4HR

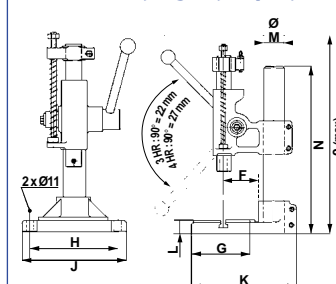

7HR

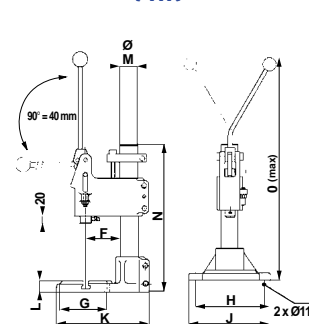

2HR - 3HR - 4HR  
5 HR - 7 HR  
15HR - 20HR

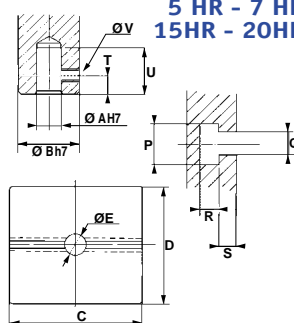

5HR - 15HR - 20HR

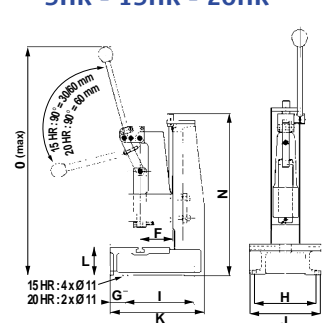

# PNEUMATICKÉ LISY



6PHR



8PHR



1T



1T LP



3T - 4,3T



3T LP - 4,3T LP - 6T

• **Nastavitelný zdvih.**

Použití pro stejné účely jako ruční lisy

	6 PHR	8 PHR	1T	1TLP	3T 4,3T	3TLP/6T 4,3TLP
A	16	20	16	16	14	14
B	35	35	30	30	30	30
C	12	12	15	15	15	15
D	26	28	26	26	30	30
E	-	22	15	15	15	15
F	-	M16	M8	M8	M8	M8
G	8	12	12	12	12	12
H	15,5	21	21	21	21	21
I	10	9	9	9	9	9
J	7,5	9	9	9	9	9
K	160	200	300	300	305	300
L	145	175	200	300	190	295
M	14	20H7	32H7	50	30	50
N	138	19,5	50	50	50	85
O	-	150	265	290	290	400
P	200	230	225	225	225	225
Q	31	55	105	120	147	150
R	250	270	340	425	550	700
S	240	260	250	270	255	300
T	400	450	510	610	-	-
U	640	870	840	955	675	800
V	G.1/4	G.3/8	G.1/2	G.1/2	G.1/2	G.1/2*

\* 6T : G.3/4

**6PHR - 8PHR**

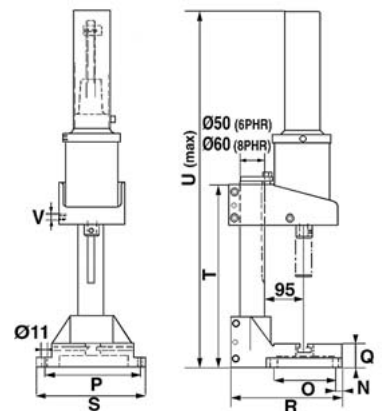

**1T - 1TLP**

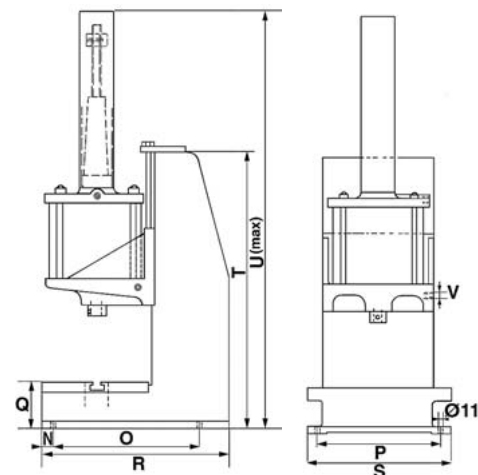

**3T - 3TLP - 4,3T - 4,3TLP - 6T**

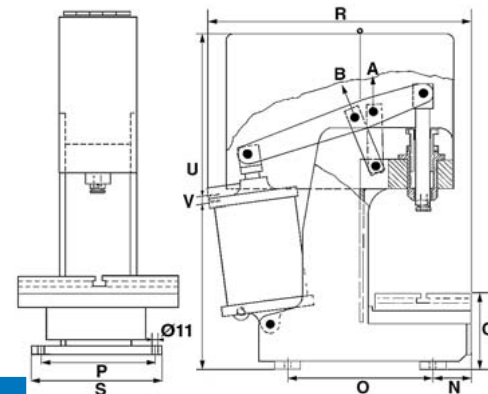

		6 PHR	8 PHR	1T	1T LP	3T	4,3T	3T LP	4,3T LP	6T
Síla	kg	360	700	1 000	1 000	A=3000 B=1900	4 300	A=3000 B=1900	4 300	6 000
Zdvih	mm	0→50	0→100	0→100	0→100	A=0→54 B=0→69	0→40	A=0→54 B=0→69	0→40	0→50
Světlá výška	mm	20→250	20→260	140→200	300	A=180 B=195	175	A=295 B=310	290	290
Hloubka	mm	95	95	100	180	110	110	180	180	180
Hmotnost	kg	25	50	125	150	150	150	200	200	230
Rychlost zdvihu	mm/sec.	150	130	100	100	A = 48 B = 75	36	A = 48 B = 75	36	40
Spotřeba vzduchu	l	1	2,5	3,5	3,5	5,2	5,2	5,2	5,2	9,8

**6PHR - 8PHR  
1T - 1TLP  
3T - 3TLP - 6T**

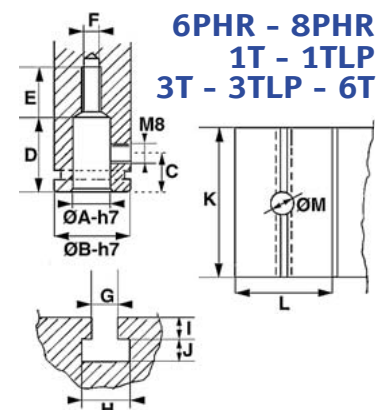

# DÍLENSKÉ HYDRAULICKÉ LISY

Ideální pro malé i velké lisařské práce jako jsou opravy, stahování a instalace těsnění či ložisek...

Pro všechny typy dílenských provozů a výrob.

Variabilní polohování lisovacího lože.

Opce- «Rychlý zdvih» ovládána pneumatickým pedálem.



**8T**

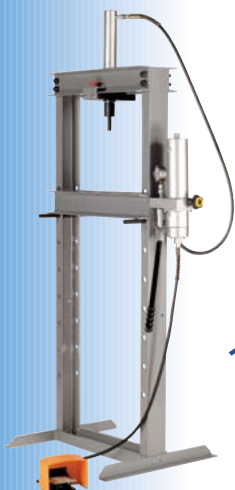

**10T**

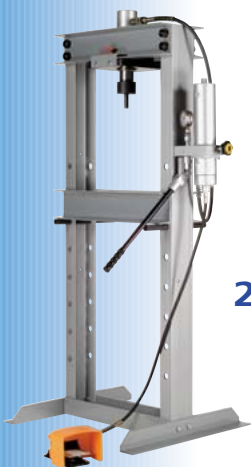

**20T**

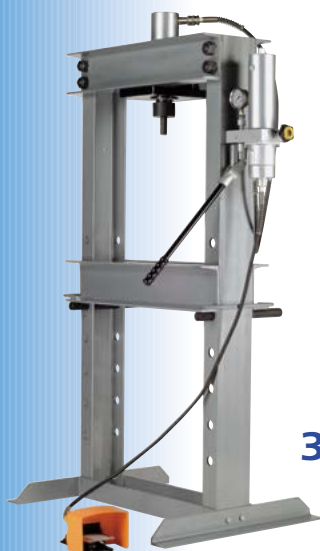

**30T**

	8 T	10 T	20 T	30 T
A	540	740	790	920
B	360	540	510	620
C	480	640	640	770
D	304	610	700	700
E	715	1650	1650	1630
F	895	1908	1735	1748
G	135	100	125	150
H	200	435	312	418
I	152	254	125	200
J	102	120	120	120
K1	160	215	232	295
K2	254	1065	1072	1015
	50 kg	95 kg	155 kg	210 kg

